

VAA NEWS

FAA Issues Rudder Stop AD on Cessna 150/152

Despite comments from the Cessna Pilots Association (CPA) and other interested parties, the FAA has issued Airworthiness Directive (AD) 2009-10-09, effective June 17, 2009, requiring the installation of a new rudder stop modification kit on all models of the slant-tail versions of the Cessna 150 and 152, or in lieu of the kit's installation, the aircraft must be placarded against intentional spins and other aerobatic maneuvers. The AD must be complied with within 100 hours of time in service (TIS) after June 17, 2009, or within the first 12 months, whichever occurs first.

Tom Carr of CPA, an experienced airframe and powerplant mechanic with decades of experience concerning Cessna aircraft maintenance, commented that since the two aircraft involved in fatal spin-related accidents cited in the proposed AD issued in 2007 were not in compliance with the aircraft's type design, the issues surrounding the proposed AD were better served by the issuance of a special airworthiness inspection bulletin (SAIB) rather than an AD. (One aircraft, which crashed in 2005, had the rudder stop installed upside down, compromising the control system's functionality; on the other accident aircraft, which crashed in Canada in 1998, the rudder most likely was pushed over by outside forces acting during the accident sequence. On that aircraft the rudder control system had known maintenance-related issues that rendered the aircraft unairworthy, yet the aircraft was still flown.)

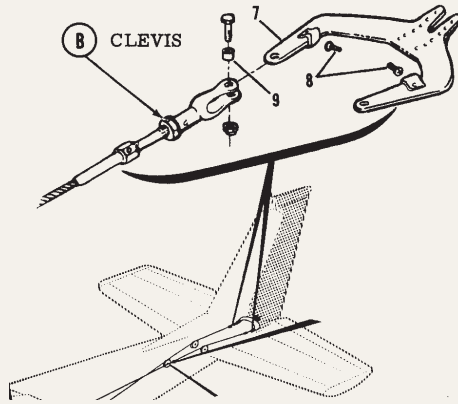

While Cessna created a modification kit in 2001 to enhance the design of the rudder stop (a kit that has subsequently been redesigned and given a new part number), there have been no failures of the aircraft's rudder control system that would lead one to believe the aircraft's type design was at fault. On the contrary, as is true with many other systems on an aircraft, if the aircraft is maintained in compliance with the type design standards, the aircraft will continue to operate as intended. But if maintenance fails to detect a failure or induces a failure of the system, then the aircraft is unairworthy. An SAIB, coupled with revised maintenance/inspection procedures, is a reasonable and prudent way to address a maintenance-related issue such as this.

For more information on the issuance of the AD, it can be viewed on the FAA's website at www.FAA.gov; click on the Regulations & Policies tab, and then click on the link for Airworthiness Directives. Enter the AD number, AD 2009-10-09, or just click on the New ADs link on the left side of the page to review the list of recently issued ADs.

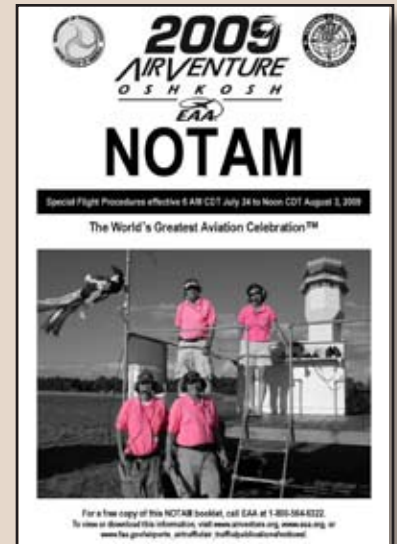

Required Equipment: EAA AirVenture NOTAM

If you're planning to fly in to Oshkosh next month, it's imperative that you obtain a copy of the FAA's 2009 AirVenture Notice to Airmen (NOTAM), which contains arrival and departure procedures for the 57th annual fly-in convention. These procedures are in effect from Friday, July 24, through Monday, August 3—one day earlier than previous years. (The event is July 27-August 2.)

While the overall procedures are similar to past years, there are some noteworthy changes—29 of the NOTAM's 32 pages contain updates. You can download a PDF version at www.AirVenture.org/flying/notam2009.pdf, or call EAA Membership Services at 800-564-6322 and a printed booklet will be mailed to you, free of charge. (Order a booklet at https://Secure.EAA.org/AirVenture/notam_request.html.)

Additional hints and tips for pilots arriving at and departing from EAA AirVenture 2009 are also available online at www.AirVenture.org/atc.

Wonderful Changes Await VAA Members in Oshkosh

When you receive this issue of *Vintage Airplane*, there will be about 50 days left to go until EAA AirVenture Oshkosh 2009. There's plenty of work to be done, with the VAA work parties completing the new Vintage Hangar, working on the Red Barn, and preparing the usual AirVenture items.

We do have a wish list, and at the top of our "I wonder if anyone has . . ." list is this:

To accommodate the members who will be attending presentations in front of the Vintage Hangar (in the space formerly occupied by the ice cream stand), we're in need of a set of bleachers. A set of three or four tiered units, either aluminum or wood, would be very helpful. The type used around a ball diamond or smaller school track meet would be perfect. (Think of the bleachers next to the cornfield in the baseball movie *Field of Dreams*.) If you can help, please give us a call here at VAA Headquarters, 920-426-6110, and let us know what you have.

For more on the ongoing construction of the Vintage Hangar and the changes in the VAA area, be sure to visit our website at www.VintageAircraft.org.



the Saturday evening show by comedian-ventriloquist Jeff Dunham, the awards ceremony for the VAA will take place in the Vintage Hangar, just south of the VAA Red Barn. The ceremony, which will take place starting at 6:30 p.m. on Saturday, after the daily air show, promises to be a great evening for winners and attendees alike. After the ceremony, we'll host a reception for all attendees and the winners in the Vintage Hangar with soft drinks and snacks. Plan on being there to cheer on your friends and enjoy some vintage camaraderie before we all head home the next day.

VAA Judging Categories

Each year we receive inquiries regarding the effective years for VAA's judging categories. Here they are:

Antique

An aircraft constructed by the original manufacturer, or its licensee, on or before **August 31, 1945**, with the exception of certain pre-World War II aircraft models that had only a small postwar production. Examples: Beechcraft Staggerwing, Fairchild 24, and Monocoupe.

Classic

An aircraft constructed by the original manufacturer, or its licensee, on or after **September 1, 1945**, up to and including **December 31, 1955**.

Contemporary

An aircraft constructed by the original manufacturer, or its licensee, on or after **January 1, 1956**, up to and including **December 31, 1970**.

Turn Your Old Parts Into New Money at Aeromart!

Did you know that AirVenture Oshkosh provides a fantastic opportunity to sell those aircraft parts cluttering up your hangar? Aeromart, the world's largest aircraft parts swap, allows you to turn old parts into cash, with the added satisfaction that you have helped other EAA

Type Clubs

We have a couple of type club additions and revisions for you:

SuperCub.Org

P.O. Box 150
Waldron, MO 64092
816-359-3540
Fax: 203-413-6360
Website: www.SuperCub.org
Dues: Donations, Min \$25/year
Publication: Online Discussion Forum

Seabee Owner's Club (IRSOC)

Steve Mestler
P.O. Box 1546
Lexington, SC 29071
E-mail: smestler@pbtcomm.net
Website: www.RepublicSeabee.com

Type Club Parking

As many of you know, a portion

of the Vintage Parking area is dedicated to Type Club Parking, an area where a rolling list of type clubs can park a select group of airplanes from their club so members and the public can enjoy seeing their unique airplanes. This year, there will be up to 30 Short Wing Pipers, 15 Cessna T-50 Bobcats, 8 Cessna 175s, and 17 Cessna 180 airplanes. Also included in this year's list is the Piper Comanche. Look for these airplanes just south of the Emergency Aircraft Repair area and the Hangar Café. Each of the aircraft in these groups is parked by special arrangement with their respective type club.

VAA Awards Ceremony

Lots of changes are in store for members who attend EAA AirVenture Oshkosh 2009. This year, due to the setup at Theater in the Woods for

members complete their projects.

Aeromart is an all-volunteer operation now run by EAA Chapter 252. It has a new location this year—right next to Camp Scholler—making it easier for campers to transport their parts to the tent for consignment sale. Simply bring over the parts you wish to sell when you arrive and register. Aeromart receives \$1 per item consigned, plus 12 percent of the sale price. All proceeds support EAA and Chapter 252.

When you leave AirVenture, stop by to pick up any unsold items, and a check from your sale proceeds will be mailed to you. It's that easy!

For more information about selling items, visit www.Aeromart.webs.com. If you are interested in volunteering at Aeromart, e-mail OshkoshAeroMart@gmail.com.

New and Improved: AirVenture Event Schedules

Online, on your phone



Each year EAA aims to provide the most accurate, up-to-date information about EAA AirVenture forums, workshops, presentations, and other scheduled events . . . and well in advance of the event to allow attendees to plan their week. This year we think we've created the most useful version yet.

Now available at www.AirVenture.org/forums, you can see the com-

Cessna Bobcat Anniversary

This past March 26 was the 70th anniversary of the maiden flight of the Cessna T-50. As shown on our back cover, the twin-engined trainer and utility airplane was piloted that Sunday morning by Cessna's Dwayne Wallace.

The Bobcat, made famous as the first airplane used in the classic television series *Sky King*, will be celebrated during a gathering in the Type Club Parking area. Jon Larson, the longtime leader of the Cessna Bobcat Type Club, tells us that he has more than a dozen confirmed Bobcats headed toward Oshkosh, with a couple more on the hopeful list.



plete presentations schedule, allowing you to peruse every scheduled event (there are more than 1,000), create and print your own personal AirVenture itinerary, and stay abreast of schedule changes that can occur during the week.

If you have a web-enabled mobile phone (or a smartphone), you will have access to the complete AirVenture schedule of events wherever you have phone service.

"In response to member requests and suggestions, we've been working hard on creating a new way to efficiently share and disseminate all the events information that AirVenture has to offer," said Mark Forss, the presentations coordinator who has shepherded the new system. "Our new 'plan your schedule' feature, coupled with the ability to look up information on a web-enabled

mobile device, is what sets this new system apart from previous efforts. The new system also gathers previously disconnected information from numerous sources and puts it into one easy-to-find place on the Web and on your phone. We anticipate these new tools being very popular among the attendees!"

Visit the AirVenture website and start planning your Oshkosh visit today!

New 406 ELT Rule in Canada Put on Hold

The upcoming transition to requiring 406 MHz emergency locator transmitters (ELTs) in nearly all general-aviation aircraft operating in Canada has been put on hold by John Baird, Canada's Minister of Transport, according to Kevin Psutka, president of the Canadian Owners and Pilots As-

sociation. Psutka met recently with Transport Canada officials arguing that the rule as written was not workable.

“The regulation as written was unachievable because the allowed alternatives do not exist,” Psutka told EAA. “My argument that this rule was immature was apparently

accepted, and the minister sent it back to CARAC (Canadian Aviation Regulation Advisory Council) for revision.”

CARAC is a joint effort of government and the aviation community including participation from organizations representing operators, manufacturers, and

professional associations.

One of the alternatives Psutka is pushing for is approval of 406 MHz personal locator beacons (PLBs) or tracking devices instead of the significantly more expensive installed ELTs.

Psutka was quick to say that this development does not eliminate the new rule. “Where it stands, the CARAC will reconvene, and my understanding is that the earliest this will happen is the third week of June,” he said. If everything went as swiftly as possible, a new final rule addressing the minister’s concerns would be announced no earlier than the end of August, he added. Meanwhile, pilots who have yet to upgrade to the 406 MHz ELTs can continue operating legally with the older 121.5 MHz units, although Psutka cautioned that search-and-rescue satellites no longer monitor the older frequency.

Denis Browne, chairman of the EAA Canadian Council, was glad to learn that the public would have more input on the rule through the CARAC. “We would like to see the end-users given more opportunity for feedback on potential alternative compliance, such as PLBs, and other ways of dealing with the new technology,” he said. “There also has not been full consideration of the effect of this new rule on international traffic and how to accommodate air tourism. The CARAC usually considers such recommendations.”

Because the FAA does not plan to adopt the 406 MHz ICAO standard in the United States, EAA feels most American aircraft owners will likely choose not to spend the estimated \$1,000 (plus installation) to equip their aircraft, resulting in a sharp decline in tourism and business flights by U.S.-registered aircraft into Canada. From May 2007 to May 2008, the Canada Border Services Agency processed more than 63,000 foreign private aircraft, roughly 90 percent U.S.-registered.

Aircraft Groups to Gather for Oshkosh Journey



As aircraft from around the world make their way to EAA AirVenture Oshkosh this summer, hundreds of aviators gather together to arrive at Wittman Regional Airport in flocks of kindred aircraft, creating their own communities along the flightline.

Groups scheduled to arrive en masse at Oshkosh in 2009 include Cessna 150s and 152s, in honor of the Cessna 150’s 50th anniversary; Beechcraft Bonanzas (Bonanzas to Oshkosh); Cessnas (Cessnas 2 Oshkosh); Mooneys (Mooney Caravan); Piper Comanches; and custom-built Van’s RV airplanes. In addition, warbirds such as the T-6, T-28, T-34, and Nanchang Red Stars will arrive as groups during the afternoon air show on Monday, July 27.

Many people come to Oshkosh early just to see these mass arrivals, scheduled July 24-26 and coordinated between EAA, the FAA, and the individual aircraft groups. Pilots in the mass arrivals receive thorough briefings prior to arriving at Oshkosh, and scheduled arrivals could be altered due to weather or other factors.

Here’s the current schedule of EAA AirVenture mass arrivals:

- Friday, July 24, 10 a.m.—Cessna 150/152 (www.Cessna150152.com)
- Saturday, July 25, 1 p.m.—Beech Bonanzas (www.B2Osh.org)
- Saturday, July 25, 2:30 p.m.—Cessnas (www.Cessnas2Oshkosh.com)
- Saturday, July 25, 4 p.m.—Mooneys (www.MooneyCaravan.com)
- Sunday, July 26, 11:30 a.m.—Piper Comanches
- Sunday, July 26, 1:30 p.m.—Van’s RVs
- Monday, July 27, 3:30 p.m.—T-6, T-28, T-34, Nanchang Red Stars